

# Ascent

## High-Throughput Fraction Collector User Manual



**everest**  
biolabs

[www.everestbiolabs.com](http://www.everestbiolabs.com)

This document is copyright protected and any reproduction of the whole or any part of this document is strictly prohibited without prior written authorization of Everest Biolabs.

This document is for reference purposes only. All information in this document is subject to change without notice.

Everest Biolabs assumes no responsibility or liability resulting from the use of this document.

For further information regarding your product, sales contract, or any information contained within this document, please contact Everest Biolabs.

Everest Biolabs  
204 Second Avenue, Suite 102  
Waltham, MA 02451, USA

Telephone: +1-617-214-0840  
Email: [support@everestbiolabs.com](mailto:support@everestbiolabs.com)  
Website: [www.everestbiolabs.com](http://www.everestbiolabs.com)

# Table of Contents

- 1. Safety And Hazards ..... 3
  - 1.1. General Precautions ..... 3
  - 1.2. Mechanical Hazards ..... 3
  - 1.3. Electrical Hazards ..... 3
  - 1.4. Chemical & Biological Hazards ..... 3
  - 1.5. Disposal ..... 4
- 2. Compliance ..... 4
  - 2.1. RoHS ..... 4
  - 2.2. CE Certification ..... 4
- 3. Ascent Overview ..... 6
  - 3.1. Ascent Specifications ..... 6
  - 3.2. Ascent Contents ..... 7
- 4. Setup Instructions ..... 8
- 5. Operating Instructions ..... 13
  - 5.1. Setting up a run ..... 14
  - 5.2. Washing Columns ..... 17
  - 5.3. Service Menu ..... 19
  - 5.4. Config Menu ..... 22
- 6. Maintenance ..... 23
  - 6.1. Water Rinse ..... 23
  - 6.2. Cleaning Waste Reservoir ..... 23
  - 6.3. Preventative Maintenance ..... 23
  - 6.4. Decontamination ..... 24
  - 6.5. Transport ..... 24
- 7. Updating Firmware ..... 26
  - 7.1. Firmware Troubleshooting ..... 28
- 8. Troubleshooting ..... 30
- 9. Change History ..... 31

## 1. Safety And Hazards

### 1.1. General Precautions



Everest Biolabs is committed to providing high-quality products that are safe for the user and the environment. Everest Biolabs has followed requirements set by the IEC 61010 series of standards harmonized under the Low-Voltage Directive (LVD). We have carefully designed this instrument to minimize potential hazards to the user.

The user should always follow the directions described in this document, as well as current Good Laboratory Practices (cGLP) and local guidelines.



Only qualified technical personnel should perform service on the instrument.

The instrument weighs 13.6 Kg/33 lbs. Caution should be used when lifting the box or instrument. Always lift with two people to avoid personal injury.

### 1.2. Mechanical Hazards



This instrument was designed with safety precautions in place and can only exert minimal force. Some areas of the instrument or its components can present pinch hazards when the instrument is operating. Keep hands and fingers clear of moving parts when the instrument is in operation. Do not open the door during operation.

### 1.3. Electrical Hazards



The instrument's power supply or power cord must be connected to a power receptacle that provides voltage and current within the specified rating for the system. The use of an incompatible power receptacle may produce electrical shock and fire hazards.

Avoid spilling liquids on the instrument; fluid seepage into internal components creates a potential for shock hazard or instrument damage. If a spill occurs while the instrument is running, abort the program and turn the instrument off. Wipe up all spills immediately. Do not operate the instrument if internal components have been exposed to fluid.

Always turn off the power switch and unplug the power supply before cleaning the outer surface of the instrument.

### 1.4. Chemical & Biological Hazards



The instrument contains no potentially harmful chemical or biological materials. Some samples may pose a biological hazard. Adequate safety precautions should be taken. Always wear proper protective equipment, such as gloves, glasses, and lab coats. Always follow current Good Laboratory Practices.

Follow all local guidelines for the proper disposal of biohazardous material.

## 1.5. Disposal



The instrument contains electronic or electrical materials; it should be disposed of as unsorted waste and must be collected separately, according to the European Union Directive: Waste Electrical and Electronic Equipment - WEEE Directive. The user is fully responsible for ensuring that the obsolete equipment and/or consumables are recycled or disposed of in accordance with this and/or any other relevant laws and regulations in the jurisdictions where the instrument is being recycled or disposed of.

## 2. Compliance

Everest Biolabs has followed requirements set by the IEC 61010 series of standards harmonized under the Low-Voltage Directive (LVD). EN 61010-2-81 lists “automatic sampler / pipettor / aliquoter” in its extended scope definition. Its general scope is defined as “automatic and semi-automatic laboratory equipment for analysis and other purposes”. According to EU law, conformity may be declared to either the Low Voltage Directive (LVD) or the Machinery Directive (MD), not both. Therefore, conformity for this instrument is declared to the LVD.

FCC Declaration of Conformance: This device complies with part 15 of the FCC Rules. Operation is subject to the following two conditions: (1) This device may not cause harmful interference (2) This device must not accept any interference received, including interference that may cause undesired operation. Changes or modifications not expressly approved by the party responsible for compliance could void the user’s authority to operate the equipment.

### 2.1. RoHS

All components and manufacturing processes used in the production of the instrument are compliant with the Restriction of Hazardous Substances (RoHS) 3 directive (2015/863/EU). The EN 62321 standard is used to verify all parts are compliant with RoHS.

### 2.2. CE Certification

Based on the testing performed and information contained herein, this instrument bears the CE mark.

## EU Declaration of Conformity

This declaration of conformity is issued under the sole responsibility of the manufacturer:

**Everest Biolabs Inc.**  
**204 Second Avenue**  
**Suite 102**  
**Waltham, MA 02451**  
**USA**



For the product: **Ascent**

This product conforms with the following European Directives:

**Directive 2004/108/EC:** Electromagnetic Compatibility

**Directive 2006/95/EC Low Voltage:** Machinery Safety

**Directive (EU) 2015/863 :** Restriction of Hazardous Substances (RoHS3)

This product has been designed and manufactured according to the following standards:

**EN 61326-1-2021:** Electrical Equipment for Measurement, Control, & Laboratory Use

**EN 61000-4-2:** Electrostatic Discharge

**EN 61000-4-3:** Radiated EM Fields

**EN 61000-4-4:** Electrical Fast Transient/Burst

**EN 61000-4-5,** Surge Immunity

**EN 61000-4-6:** Conducted Disturbances from RFI

**EN 61000-4-11:** Voltage Dips, Short Interruptions and Variations

**EN 61010-1:** Safety requirement for electrical equipment for measurement, control and laboratory use. Part 1, General requirements

**EN 61010-2-081:** Particular requirements for automatic and semi-automatic laboratory equipment for analysis and other purposes

**EN IEC 63000:2018:** Technical documentation for the assessment of electrical and electronic products with respect to the restriction of hazardous substances

Name and address of the person authorized to compile the technical file:

**Everest Biolabs Inc., 204 Second Avenue, Suite 102, Waltham, MA 02451**

X *David Freedman*

David Freedman  
President and COO

X *Steven Scherr*

Steven Scherr  
VP of Product Development

### 3. Ascent Overview

#### 3.1. Ascent Specifications

##### ASCENT INSTRUMENT SPECIFICATIONS

<b>Dimensions (WxDxH)</b>	397mm x 364mm x 331mm (15-5/8" x 14-5/8" x 13")
<b>Weight</b>	13.6 Kg/ 30.0 lbs
<b>Input Power</b>	100~240 VAC (50-60Hz)
<b>Power Supply Unit</b>	24 VDC, 2.1A, 50W
<b>Environmental Temperature</b>	10°C -24°C (50°F-75°F)
<b>Relative Humidity</b>	30-80% RH
<b>User Interface</b>	120.7mm x 75.8mm
<b>Bottle Capacity</b>	1000mL
<b>Connectivity</b>	USB 3.1
<b>Chemical Compatibility</b>	PBS, DI, 70% ethanol, dilute sodium hypochlorite, NaOH

COLUMN COMPATIBILITY	COLUMN RACK POSITION	TUBE RACK CONFIGURATION
Apex 4B	Bottom	Tube Rack + Platform
Apex 6B	Bottom	Tube Rack + Platform
Apex MM	Bottom	Tube Rack + Platform
Apex mini	Bottom	Tube Rack + Platform
Izon qEVoriginal †	Bottom	Tube Rack + Platform
Izon qEVsingle*†	Bottom*	Tube Rack Only
Izon qEV1 †	Top	Tube Rack Only

\*Column Adapter required

†qEV™ is a trademark of Izon Science®; not affiliated

### 3.2. Ascent Contents

Inspect the shipping box and contents for signs of damage upon arrival. If the instrument is damaged upon arrival, notify the carrier and Everest Biolabs to resolve the issue.

#### BOX CONTENTS

Ascent Instrument
Buffer Bottles (Qty. 3) – Buffer, Water, Waste
Tube Rack
Tube Rack Platform
Apex Column Holder
Apex mini Column Holder
qEV Column Holder
Power Supply and Cable
Column Holder
Drop Catcher
USB-C Cable
Waste Splash Guard
qEVsingle Adapter (Optional Accessory)

#### COLUMN RACK POSITION

\*Apex Configuration Shown

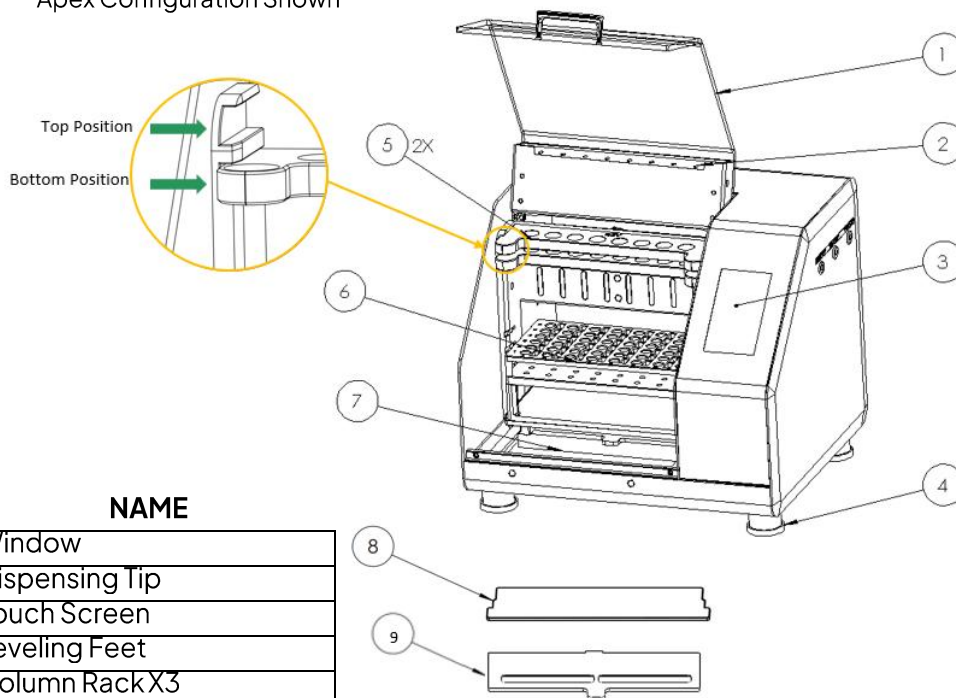

ITEM	NAME
1	Window
2	Dispensing Tip
3	Touch Screen
4	Leveling Feet
5	Column Rack X3
6	Tube Rack
7	Tube Rack Platform
8	Drop Catcher
9	Waste Splash Guard

## Setup Instructions



The Ascent instrument is heavy. Caution should be used when lifting the box or instrument. Always lift with two people to avoid injury.

1. Remove all accessories from the Ascent shipping box and place them on the bench.
2. Verify all accessories are present as you remove them from the box.
3. Remove the instrument from the box in the plastic bag and place it on the ground.
4. Open and roll the plastic bag down to access the instrument.
5. Carefully lift the instrument out of the bag and place it on a stable and level bench.
6. Do not place the instrument in direct sunlight.
7. Remove the shipping tape holding the carriage.
8. Connect each bottle to the corresponding tubing. Firmly press the tubing into the push-to-connect fitting until they bottom out.
9. Place the waste splash guard on the waste reservoir and make sure it is securely in position.
10. Plug the power supply and cable into a compatible power source and into the power input on the back of the instrument.
11. You may now turn on the instrument using the rocker switch located in the back right of the instrument. You should verify that the touch screen turns on and is not damaged upon startup.

## Self-Test Instructions

Unbox the Ascent and perform the self-test to ensure the product is functional. When the instrument is removed from the box perform a visual inspection for damage during shipping. Check the door for and screen for cracks, and ensure there are no loose parts visible

1. Turn on the instrument power switch.
2. In the Run menu, change the number of columns from 1 to 8. This should light up all 8 LED bars white.

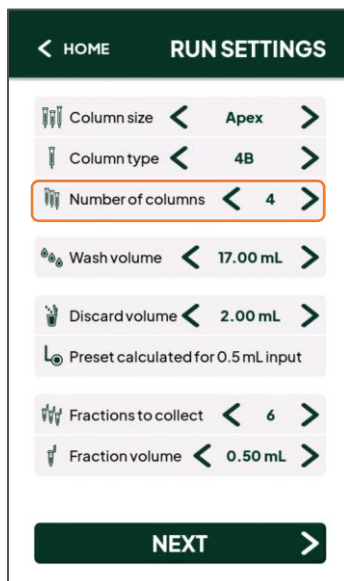

3. In the 5th Service menu page, check that the limit switches are triggered. Load two column racks into the instrument, one into the top location and one in bottom. Close the door to check the door limit switch. Press the Door Lock button and ensure the lock actuates and releases.

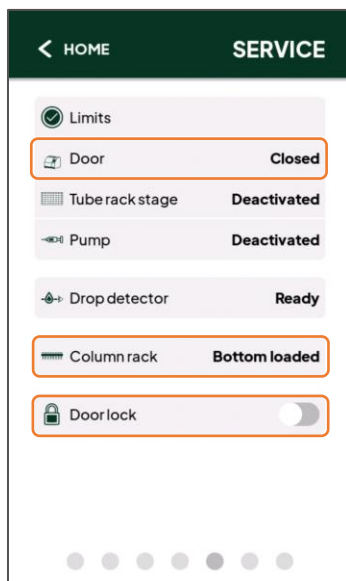

- In the 3<sup>rd</sup> page of the Service menu toggle each valve open and close. Make sure the toggle actuates and return. You may hear a click when actuating the valve.

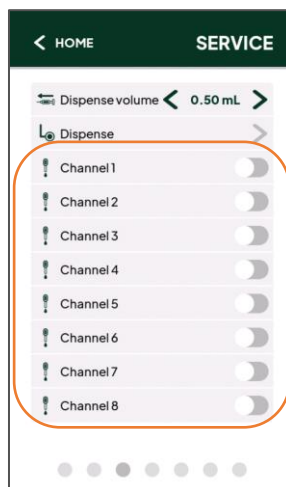

- In the 4<sup>th</sup> page of the Service menu toggle waste pump and waste valve open and close. Make sure the toggle actuates and return. You should hear the pump turn on and off.

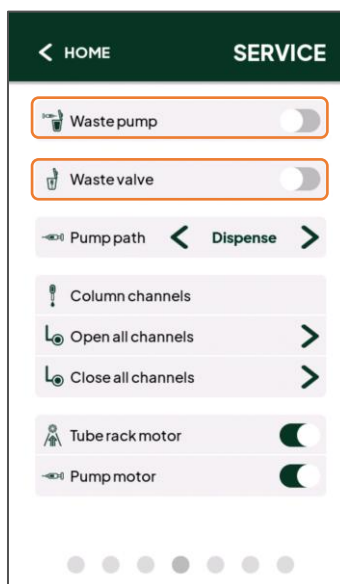

- Press “Initialize Hardware” to prime the instrument on the 1st Service menu page. Ensure the carriage travels to the rear of the instrument.

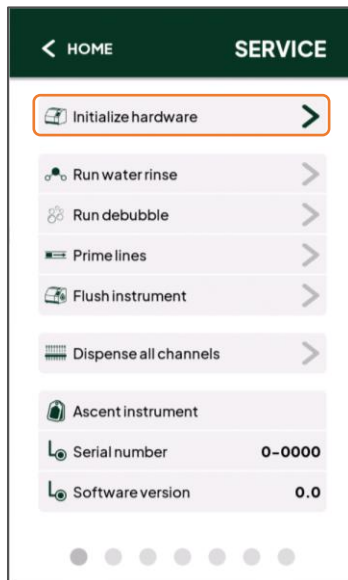

- Using the 2<sup>nd</sup> page of the Service menu, intake 5 mL from Water into the pump. You should hear the pump move and see liquid flow into the line.

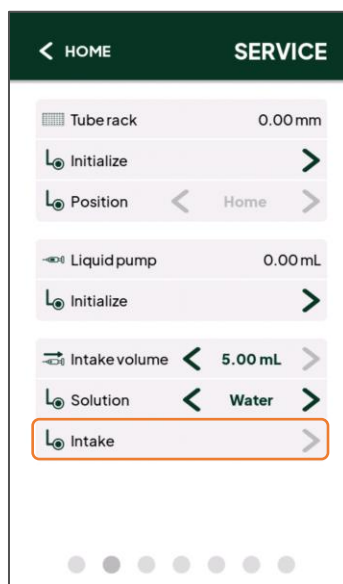

8. **Close the door.** From the 1st page of the service menu, dispense all channels. Ensure liquid comes out of each tip into the waste.

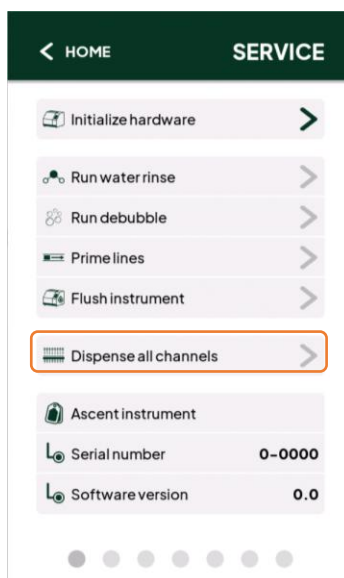

## 4. Operating Instructions

The Ascent instrument is controlled by the onboard touch screen. The "HOME" screen is visible when you power on the instrument. From this screen, you have four options: RUN, WASH, CONFIG, and SERVICE.

1. The **RUN** button (sect. 5.1) guides you through the steps for collecting fractions from SEC columns. Recommended collection parameters for Apex (and other) SEC columns are programmed into the instrument for easy operation. All parameters can be configured for your application. You can run from 1-8 columns and collect up to 12 fractions per column. The tube rack is designed for collecting up to 6 fractions per column. To collect more than 6 fractions, refer to the end of section 5.1.

We recommend a minimum of 1mL wash volume when collecting fractions to ensure the liquid is completely primed to the end of the dispensing tips before collecting fractions.

Additional options include a post-run column wash, column saver, and instrument water rinse. The post-run column wash rinses the columns with a configurable volume of buffer after the collection is complete. The instrument water rinse flushes the fluidic lines with water to reduce salt buildup. We recommend enabling this feature. The column-saver feature keeps columns from drying out if left unattended. It dispenses small volumes of buffer when waiting to add samples and at the end of a run.

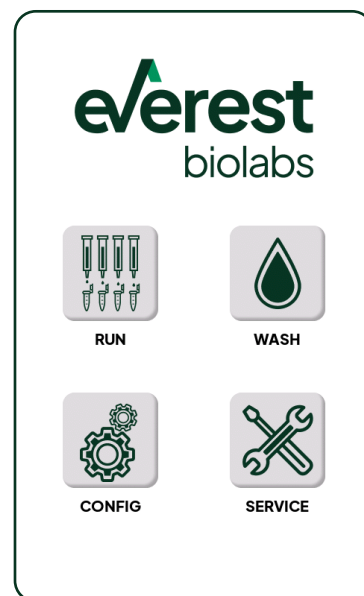

2. The **WASH** button (sect. 5.2) automates the process of washing SEC columns with working buffer. This is a standalone feature that lets you wash columns without performing a collection.
3. The **SERVICE** button (sect. 5.3) lets you control the individual functions of the instrument hardware. The Service screen is used for maintenance (sect. 6) and troubleshooting (sect. 8). From here you can initialize the hardware and control the pumps, valves, and motors. You can also turn on the droplet detectors from this menu. The service menu isn't needed during normal operation.
4. The **CONFIG** button (sect. 5.4) lets you set and save instrument features. You can enable/disable audio alerts, column lights, and the screen saver. You can also adjust the wash resolution and drop detection options. The drop timeout default waits 15 seconds after dripping stops to proceed to the next step. For viscous samples, you can increase the drop timeout.

## 4.1. Setting up a run

1. From the home screen press the “RUN” button.

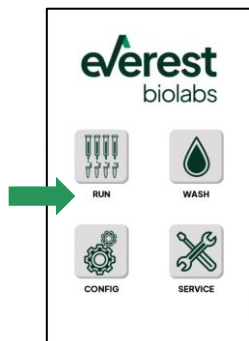

2. On the “RUN SETTINGS” screen, configure your collection parameters. First, select the column type. The remaining settings will populate with recommended values. You may adjust these values for your application

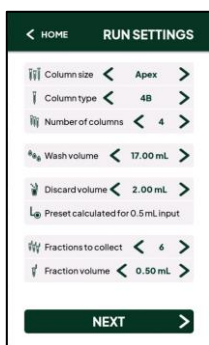

- a. Column size – Apex, Apex mini, qEVoriginal, qEV1, qEVsingle
- b. Column type – 4B, 6B, MM, 20, 35, 70
- c. Number of columns – 1 to 8 columns
- d. Wash Volume – 0-40 mL
- e. Discard Volume – 0-10 mL
- f. Number of Fractions to Collect – 1-12
- g. Fraction Volume – 0.1-2.0 mL

3. Select “NEXT” to go to the “OTHER OPTIONS” screen. This screen lets you set the additional options:

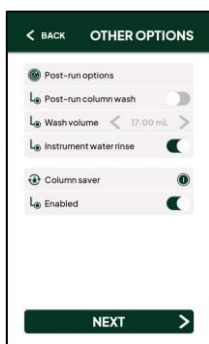

Post-run options:

- Enable post-run column wash
- Set volume of post-run column wash
- Enable water rinse of the instrument
- Enable/disable column saver

**The *Column Saver* option will prevent columns from drying out if left unattended. It is used while waiting for samples to be added and at the end of a run.**

4. Select “NEXT” to go to the “CHECKBOTTLES” screen where you must confirm that the buffer bottle, water bottle, and waste bottle have sufficient volume for the collection.



For buffer preparation see the APEX user guide.

5. After the instrument is initialized, load the Tube Rack into the instrument. For Apex and qEVOriginal columns place the Tube Rack on the Tube Rack Platform. For qEV1 and qEVsingle, use the Tube Rack alone.

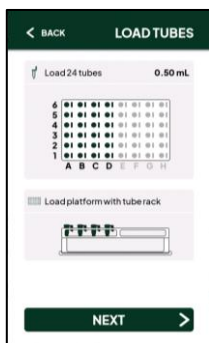

When the tube rack is loaded, and the door is closed, you can proceed to the next screen.

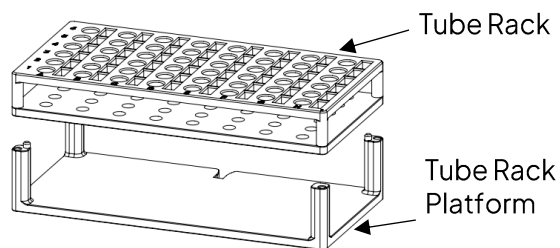

6. Remove the top cap of the columns and place them in the instrument. Apex, qEVOriginal, and qEVsingle columns use the bottom column rack position. qEV1 columns go in the top position. Remove the tip caps before proceeding.

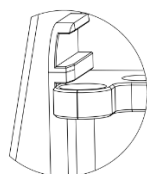
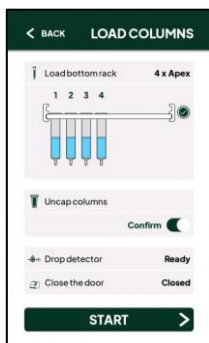

**NOTE:** You should visually check the drip speed of columns. If any column drips slower than the rest, replace it before proceeding.

**NOTE:** The column rack must be in the correct position with the door closed to proceed. Apex configuration is shown.

7. The “PROGRESS” screen shows the steps the instrument will perform, along with the current step, and experimental time.



When prompted, add samples and close the door. The instrument will collect the fractions and alert you when the collection is complete.

8. The “ADD SAMPLES” screen lets you know it is time to open the door and add your samples to the columns.

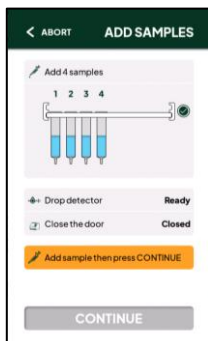

When the samples are added, close the door and select “CONTINUE” to proceed to the next screen.

9. The “COMPLETE” screen shows the steps the instrument has performed and the experimental time.

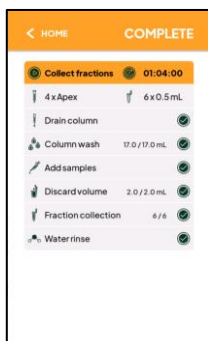

## COLLECTING MORE THAN 6 FRACTIONS

The Ascent Tube Rack is designed to collect up to 6 fractions on 8 columns. To collect more than 6 fractions, follow the software prompt and insert the drop catcher in the slots on either side. The Drop catcher should be between the tubes and column tips as shown below. Replace the Tube Rack and continue.

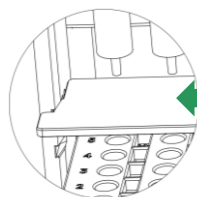
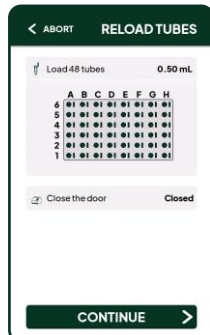

Slide Drop Catcher in from the front.

## 4.2. Washing Columns



1. From the “HOME” Screen press the “WASH” button

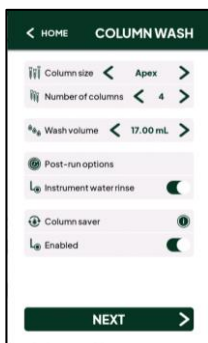

2. The “COLUMN WASH” screen lets you set the following:

- a. Column size
- b. Number of columns
- c. Wash Volume (*volume of buffer added into column before sample*)
- d. Discard Volume (*Volume of buffer added after sample before particles start eluting*)
- e. Number of Fractions to Collect
- f. Fraction Volume (*volume of eluent that is collected in single fraction*)

When selecting a column type, the remaining settings will populate with recommended values.



3. Select “NEXT” to go to the “CHECK BOTTLES” screen where you must confirm that the buffer bottle, water bottle, and waste bottle have sufficient volume for the collection.

For buffer preparation see the Apex user guide.

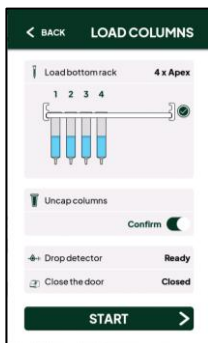

4. Remove the top cap of the columns and place them in the instrument. Apex, qEVOOriginal, and qEVsingle columns require the Column Rack to be placed in the bottom column rack position. qEV1 columns go in the top position. Remove the tip caps before proceeding. qEVsingle columns require qEVsingle adapters which are available from Everest Biolabs.

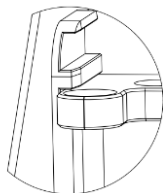

**NOTE:** The column rack must be in the correct position with the door closed to proceed. Apex configuration is shown.



5. The “PROGRESS” screen shows the steps the instrument will perform, along with the current step, and experimental time.



6. The “COMPLETE” screen shows the steps the instrument has performed and the run time.

You can now open the door and remove the washed columns.

Press the HOME button in the top left corner to return the HOME screen.

### 4.3. Service Menu



1. From the “HOME” Screen press the “SERVICE” button

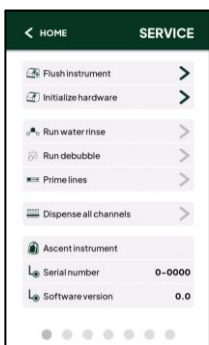

2. In the first “SERVICE” screen you can see the software version and date that is currently loaded on your instrument.

From this screen you can also initialize the hardware, run an instrument water rinse, debubble, prime the fluidic lines, flush the fluidic lines, as well as dispense out of all channels.

Other pages can be found by swiping on the screen.



3. In the second “SERVICE” screen you can:
  - a. Initialize the Tube rack and move it to a new position
  - b. Initialize the Liquid pump and prime the fluidic lines.
  - c. Set the intake volume, select between water and buffer, and intake (fill) the pump with the desired fluid and volume.

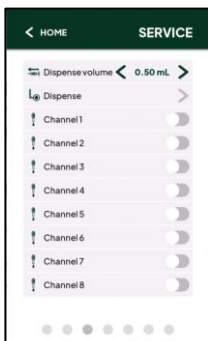

4. The third “SERVICE” screen allows you to set a dispense volume and open or close any of the 8 channels (columns). Once a channel switch is enabled/open, you may click the dispense arrow to dispense the selected volume into that column.

**You should only dispense from one channel at a time to avoid inaccuracy.**

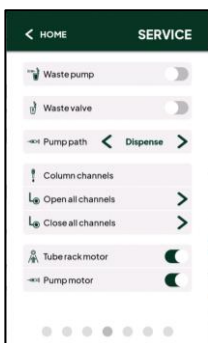

5. The fourth “SERVICE” screen allows you to:
  - a. Turn on/off the Waste pump
  - b. Turn on/off the Waste valve
  - c. Select the pump path (Dispense/Intake)
  - d. Open/Close all channels
  - e. Disable/Enable the tube rack motor
  - f. Disable/Enable the Pump motor

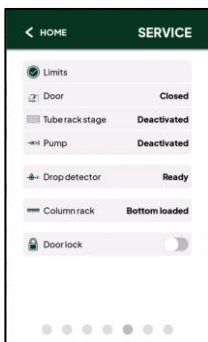

6. In the fifth “SERVICE” screen you can check the status of the limit switches for the:
  - a. Door
  - b. Tube rack
  - c. Pump
  - d. Column rack

You can also toggle the Door lock.

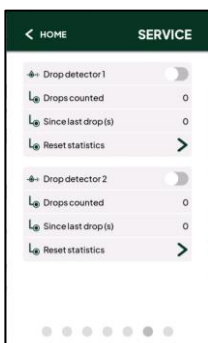

7. In the sixth “SERVICE” screen you can enable drop detectors 1 or 2 (bottom two detectors).

When the Drop detector switch is toggled, it will count the number of droplets and the time since the last droplet. You may reset these values with the Reset statistics arrow.

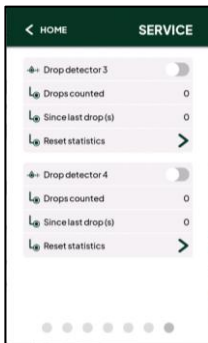

8. In the seventh “SERVICE” screen you can enable drop detectors 3 or 4 (top two detectors).

When the Drop detector switch is toggled, it will count the number of droplets and the time since the last droplet. You may reset these values with the Reset statistics arrow.

## 4.4. Config Menu

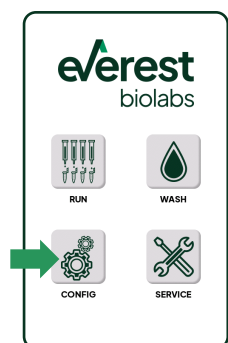

1. From the “HOME” Screen, press the “CONFIG” button

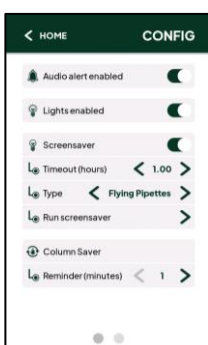

2. The first “CONFIG” screen allows you to enable:
  - a. Audio Alerts
  - b. Column Lights
  - c. Screen saver
  - d. Column saver

You may also set the timeout and type of screen saver you would like once enabled.

The screensaver will not run when a Run or Wash is active.



3. The second “CONFIG” screen allows you to see the resolution for the washes.
  - a. Timeout A default: 15 seconds
  - b. Timeout B default: 25 seconds
  - c. Timeout C default: 45 seconds

You can also set the drop timeout. This is used for highly viscous samples that drip more slowly and may require more time to allow the columns to stop dripping before proceeding to the next step. Refer to the table below for the specific column timeout settings.

COLUMN	WASH TIMEOUT	DRAIN, SAMPLE, & FRACTION COLLECTION TIMEOUT
Apex 4B	Timeout A	Timeout B
Apex 6B	Timeout A	Timeout B
Apex MM	Timeout C	Timeout B
Apex mini MM	Timeout B	Timeout C
Izon qEVoriginal	Timeout A	Timeout B
Izon qEVsingle	Timeout C	Timeout C
Izon qEV1	Timeout A	Timeout B

## 5. Maintenance

Regular maintenance is required to achieve optimal performance on the Ascent instrument. This section provides guidelines and instructions for regular and maintenance.

### 5.1. Water Rinse

The Ascent instrument has a built-in feature that flushes the fluidic lines and dispensing needles with water at the end of every run. We recommend leaving the water rinse feature always turned on as it can prevent buildup of salt or other material and reduce the likelihood of clogs or poor performance.

### 5.2. Cleaning Waste Reservoir

The waste reservoir on the base of the instrument may appear dirty due to dried salt build up. Cleaning the waste reservoir should be done monthly or any time it appears visually dirty. To clean the waste reservoir:

1. Navigate to the second service screen.
2. Toggle the *Position* until it reaches *Home*.
3. Open the door and clean the surface of the waste reservoir, rails, and nearby surfaces using 70% ethanol and a non-abrasive laboratory wipe or clean rag.

### 5.3. Preventative Maintenance

Preventative maintenance should be performed monthly under normal use or as needed to avoid contamination. To perform preventative maintenance:

1. Follow the instructions above for cleaning the waste reservoir.
2. Fill the Buffer bottle with 200 mL of 0.5% sodium hypochlorite solution (10% bleach) and re-connect the tubing.
3. Navigate to the first service screen and *Prime Lines* two times.
4. Let the fluid sit for 10 minutes.
5. Replace the sodium hypochlorite solution in the buffer bottle with water. Make sure to thoroughly wash the bottle.
6. Navigate to the first service screen and *Flush Instrument*.
7. Replace the remaining fluid in the buffer bottle with working buffer (PBS).
8. Navigate to the first service screen and *Flush Instrument*.
9. Using a non-abrasive laboratory wipe or clean rag, gently clean the dispensing needles with 70% ethanol.

## 5.4. Decontamination

To decontaminate the surfaces of the instrument, ensure that the instrument is turned off and unplugged. The entire instrument exterior and interior may be cleaned with 70% ethanol using a non-abrasive laboratory wipe or towel.

To decontaminate the fluidic lines:

1. Fill the Buffer bottle with 200 mL of 0.5% sodium hypochlorite solution and re-connect the tubing.
2. Navigate to the second service screen and *Prime Lines* two times.
3. Let the fluid sit for 1 hour.
4. Replace the sodium hypochlorite solution in the buffer bottle with water. Make sure to thoroughly wash the bottle.
5. Navigate to the first service screen and *Flush Instrument*.
6. Disconnect and empty the bottle. Do not reconnect it.
7. Navigate to the second service screen and *Flush Instrument*. This will flush the remaining liquid out of the lines.

## 5.5. Post run column wash

To regenerate columns after run, we recommend washing with NaOH with the following procedure.

1. Add 4 mL of 0.5M Sodium Hydroxide to the column.
2. Navigate to the wash menu and select your number of columns with a wash volume of 17 mL and start the wash. Allow the wash to finish and then cap the bottom of the column.
3. For long-term storage at room temperature, fill column with buffer with 0.05% Sodium Azide, 0.05% of ProClin 300, or 20% Ethanol in PBS.
4. If bactericide is not used, store columns at 2-80 C.

## 5.6. Transport

Before moving or transporting the Ascent instrument, decontamination should be performed and then the lines should be dried out.

To dry out the fluidic lines:

1. Navigate to the service screen and press “Initialize Instrument”
2. Unplug the connector from the buffer and water bottles, leaving only the waste bottle connected.
3. Navigate to the second service screen and press “Prime Lines” twice.
4. Navigate to the second service screen and select “Water” as fluid.
5. Navigate to the second service screen and press “Prime Lines” twice.
6. Unplug the connector from the waste bottle.

Always use the supplied packaging material for transporting the instrument to prevent damage during shipment. If you do not have the provided packaging material, contact Everest Biolabs for support.

With the instrument powered off, slide the carriage to the front of the instrument and remove the tube rack, tube rack platform, and column holder. Using packaging tape, secure the carriage to the front of the instrument. Close the door and place the instrument in the provided plastic bag before placing it in the carton.

## 6. Updating Firmware

This procedure requires a Window (x64) computer with a USB port and a USB-C cable to connect to the instrument.

**Note: The USB-C cable may be orientation dependent. If the instrument is not recognized when connected to the computer, flip the USB-C connector where it is plugged into the instrument.**

1. Download or copy installer package onto the computer to be used for installation (<https://everestbiolabs.com/support/>).
2. Unzip the file.
3. Connect the USB between the computer and the instrument and turn on instrument power.

**Note: The USB-C cable may be orientation dependent.**

4. Open the unzipped folder and double-click the AscentInstaller.bat file.

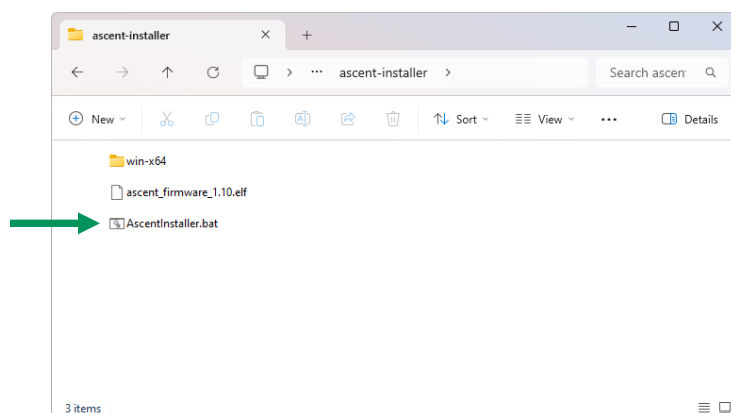

5. For updating an instrument, click 'Next' to continue.

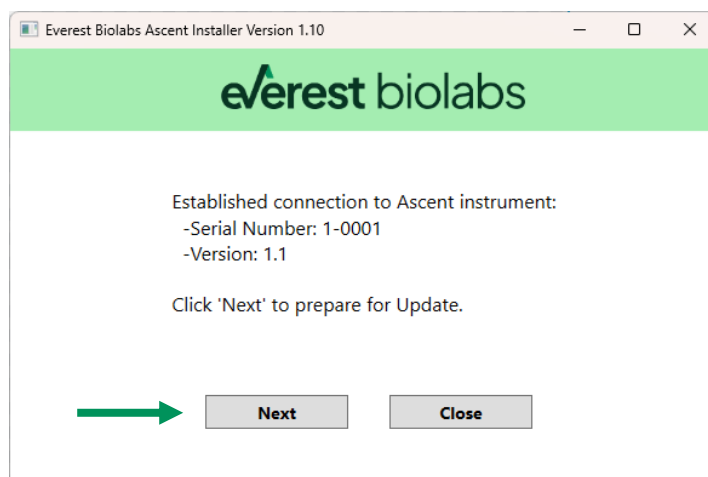

6. Click 'Install' when ready. It will take approximately 1 minute for the firmware to be downloaded to the instrument. Do not disconnect the cable or turn off the instrument power until it is complete.

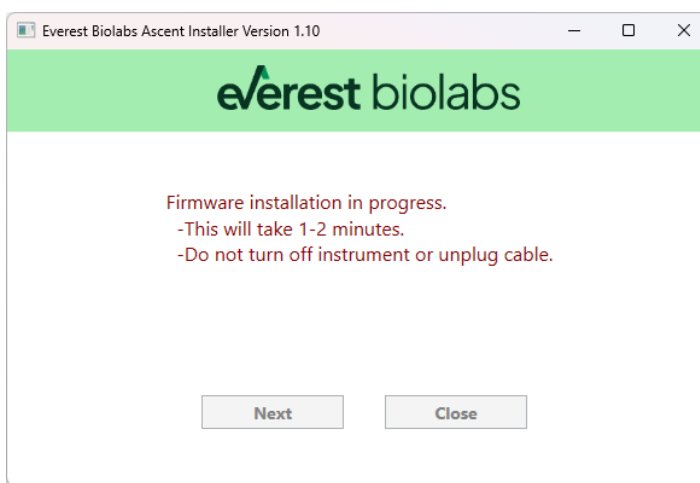
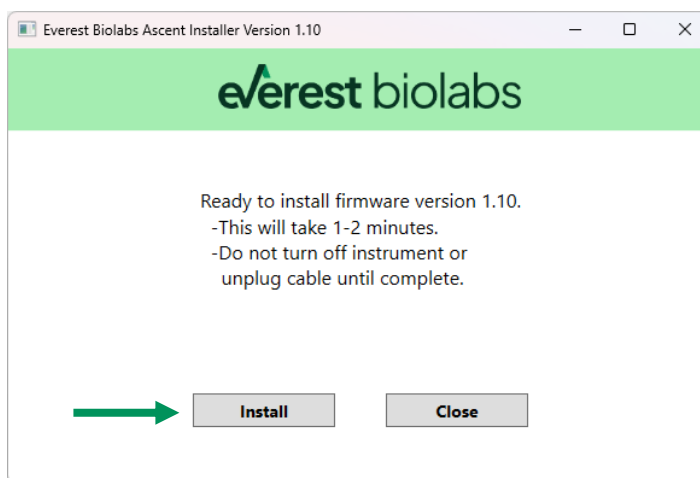

7. If installation completes successfully, close the program and disconnect the USB cable.

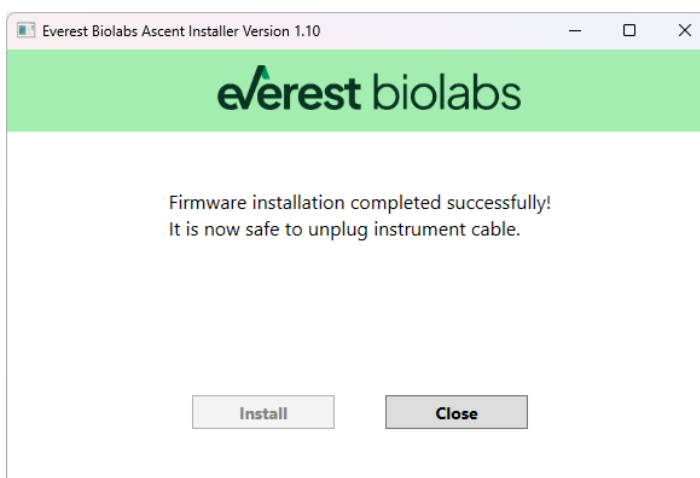

## 6.1. Firmware Troubleshooting

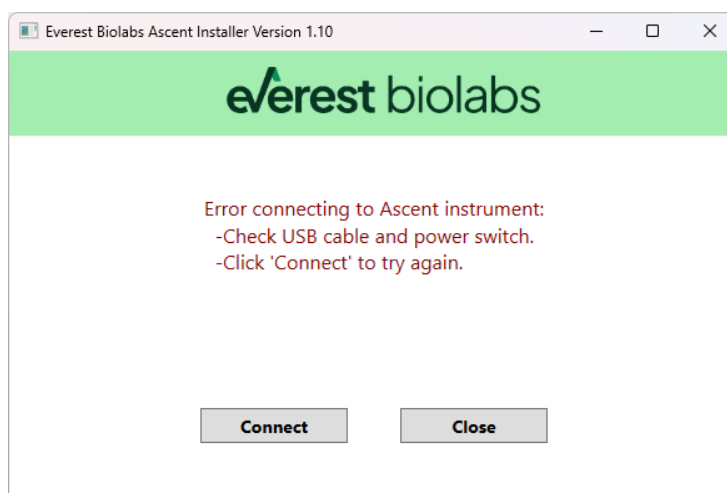

1. If the program fails to connect to the instrument at startup, confirm that the USB cable is connected, and the instrument is powered. Then click 'Connect'.
2. If the instrument still does not connect, flip the USB connector where it plugs into the back of the instrument. Then click 'Connect'.
3. If the firmware installation file is not found, confirm that the .elf firmware binary file is included in the installer folder from step 4.3. The filename should have the version number at the end (major and minor).

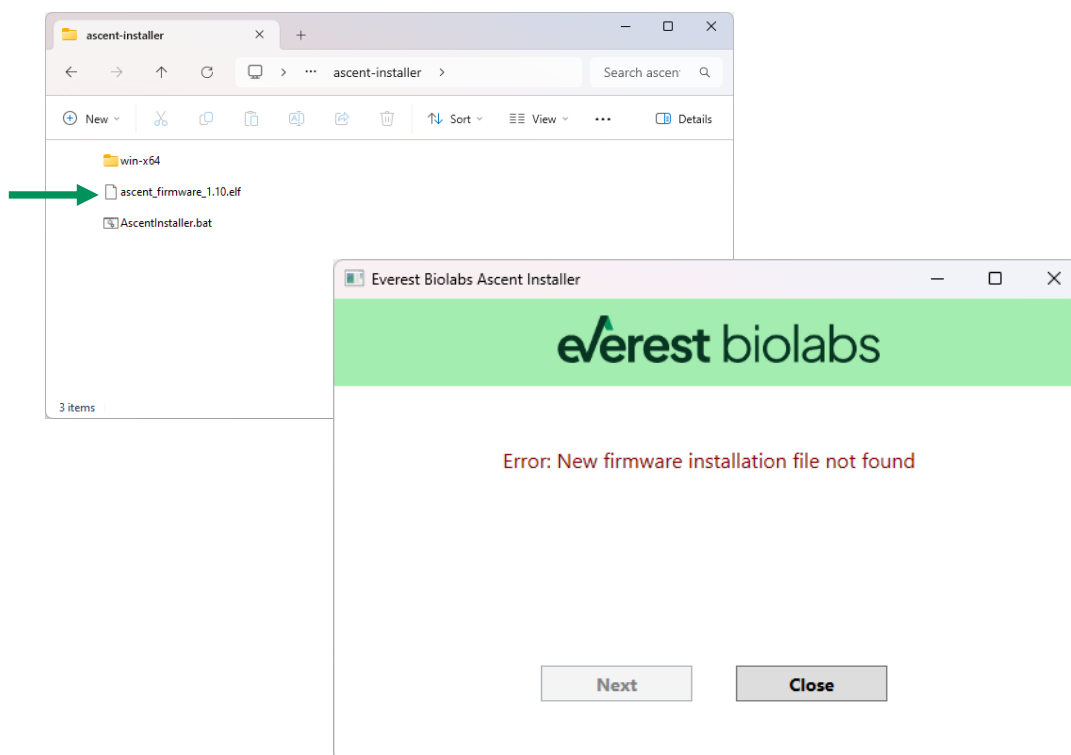

4. If an error occurs during the firmware download to the board, check the connections and try again. If the problem persists, open the win-x64 folder shown above and open the ascent\_installer.log file and inspect it for error messages.

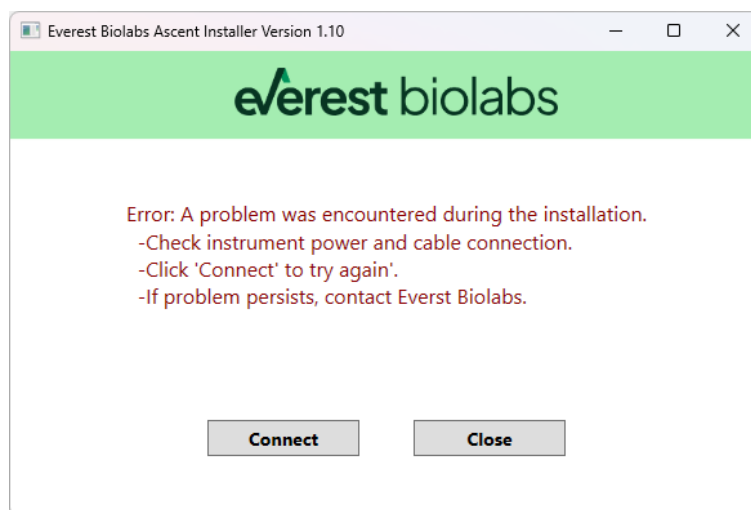

## 7. Troubleshooting

Problem	Possible Cause	What To Do
<b>Liquid not dispensing properly</b>	<ul style="list-style-type: none"> <li>Bottles may be out of liquid</li> <li>Connector on bottle may not be connected properly</li> <li>Salt build-up in dispensing needles</li> </ul>	<ul style="list-style-type: none"> <li>Refill buffer and empty waste</li> <li>Remove and re-connect the tubing. Ensure it is pushed in until it stops, and no bubbles are seen in the tube during priming</li> <li>Flush each valve individually with water from the service menu</li> </ul>
<b>Liquid not pulling from Buffer and/or Water bottles</b>	<ul style="list-style-type: none"> <li>Loose connection between tubing connectors in cap</li> </ul>	<ul style="list-style-type: none"> <li>Remove and re-insert tubing from the push to connect fittings on the top and bottom part of bottle cap</li> </ul>
<b>Stage not moving, making loud noise, and not going to expected position</b>	<ul style="list-style-type: none"> <li>Stage failed to home correctly</li> <li>Salt build up on stage rails</li> </ul>	<ul style="list-style-type: none"> <li>Power cycle the instrument</li> <li>Wipe stage rails with DI wetted Kimwipe</li> </ul>
<b>Run will not proceed</b>	<ul style="list-style-type: none"> <li>Column holder is in the wrong position</li> <li>Tube rack/platform incorrect</li> <li>Door not closed</li> </ul>	<ul style="list-style-type: none"> <li>Ensure the column holder is in the correct slot</li> <li>Ensure the tube rack platform is used if appropriate</li> <li>Open and close door</li> </ul>
<b>LEDs are not turning on or show random colors</b>	<ul style="list-style-type: none"> <li>Loose electrical connection</li> <li>Electrostatic discharge damaged electronics</li> <li>Water damaged electronics</li> </ul>	<ul style="list-style-type: none"> <li>Contact Everest Biolabs for assistance</li> </ul>
<b>Fractions are not expected volume</b>	<ul style="list-style-type: none"> <li>Not enough buffer in bottle</li> <li>Tubes not seated properly in tube rack, blocking drop detector</li> </ul>	<ul style="list-style-type: none"> <li>Fill buffer bottle to appropriate volume</li> <li>Ensure all tubes are pressed down and seated into tube rack</li> </ul>

If your problem is not listed, power cycle the instrument by toggling the power button on the rear of the instrument.

If your problem was not resolved by the troubleshooting options, please contact Everest Biolabs or report any issues at [www.everestbiolabs.com/support/](http://www.everestbiolabs.com/support/).

## 8. Change History

Ver.	Change Order	Description of Change
0	DOC-010	Initial Release
1	DOC-010	Firmware update instructions added
2	DOC-010	Updated service screen, added splash guard, updated for 2 column racks
3	DOC-010	Added definitions for wash volume, discard volume, and fraction volume
4	DOC-010	Added troubleshooting guide updates related to stage issues, unexpected fraction volume, and loose bottle tubing
5	DOC-010	Added steps for removing liquid from lines before transport, add in NaOH wash to columns
6	DOC-010	Update GUI for software release. Added Apex MM and mini compatibility
7	DOC-010	Updated Apex mini timeouts and added NaOH compatibility.